

XTOOL | Safety Set

使用者手冊

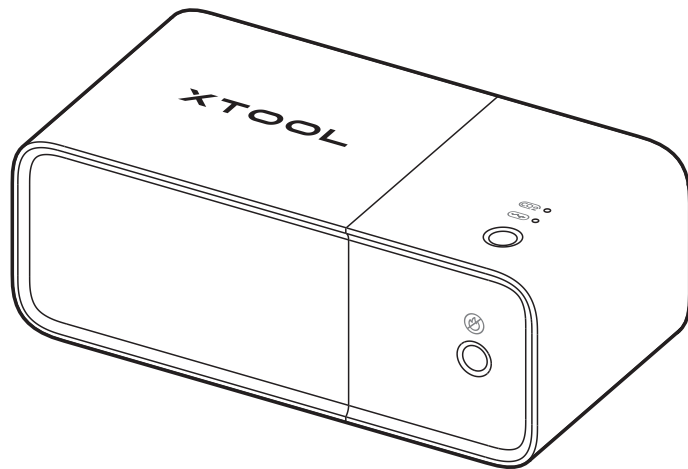

概述	01
規格參數	01
物品清單	02
認識火焰安全裝置	03
安裝火焰安全裝置	04
安裝氣瓶	04
使用火焰安全裝置	06
一鍵滅火	07
更換氣瓶	08

概述

xTool 火焰安全裝置專為具有火焰偵測功能的桌上型雷射加工產品設計，當它從雷射設備收到較大火焰信號，會自動完成從監測到滅火的全部過程。

規格參數

工作環境溫度	0°C~35°C
存放溫度	0°C~45°C
支援的最大加工空間	0.13 立方公尺

物品清單

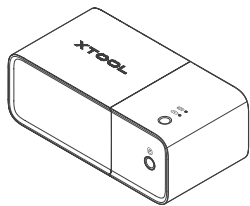

控制盒

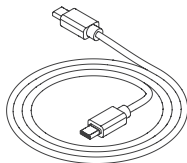

USB 連接線

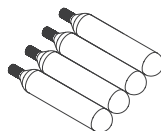

氣瓶

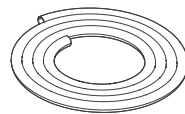

氣管

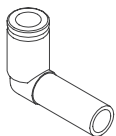

氣管接頭



使用者手冊



安全說明

認識火焰安全裝置

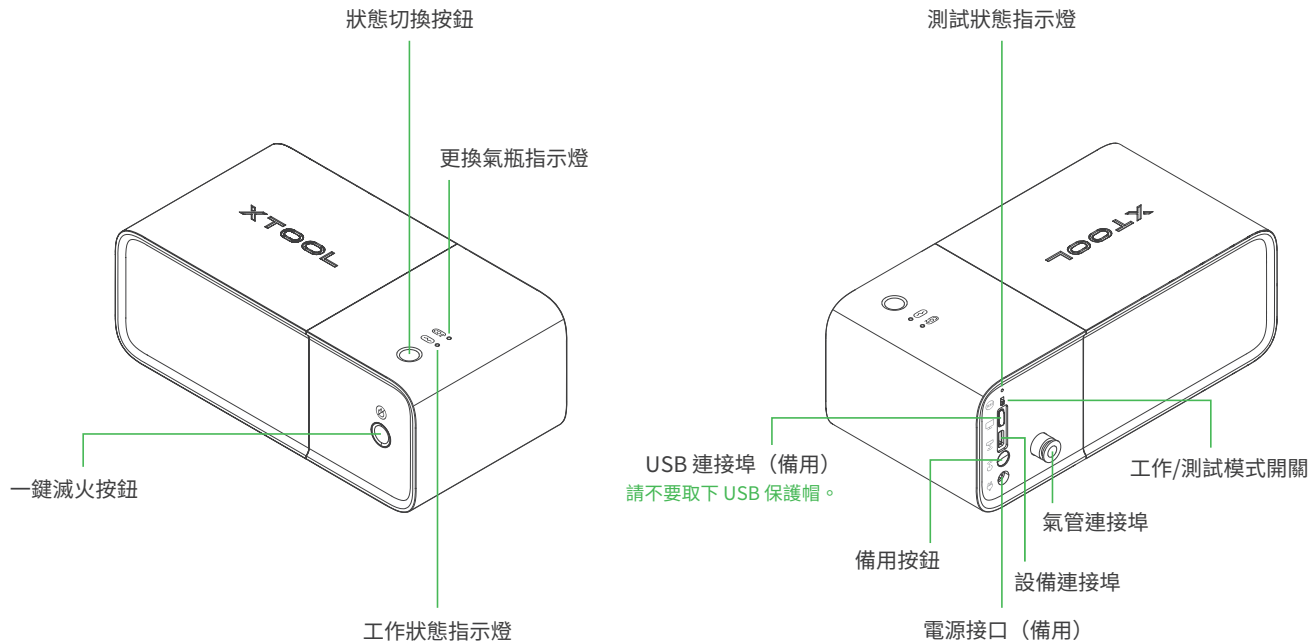

安裝火焰安全裝置

火焰安全裝置的安裝方式以實際設備為準。

若使用 xTool 設備，請前往 support.xtool.com/product/17 或掃描下方 QR code，查看火焰安全裝置的詳細安裝步驟。



support.xtool.com/product/17

安裝氣瓶



在安裝氣瓶前，請先拔出 USB 傳輸線，避免在安裝過程中誤觸一鍵滅火按鈕，導致觸發滅火動作。

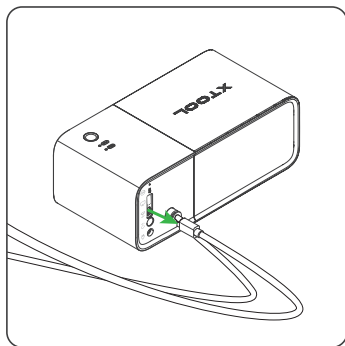

拔出 USB 傳輸線

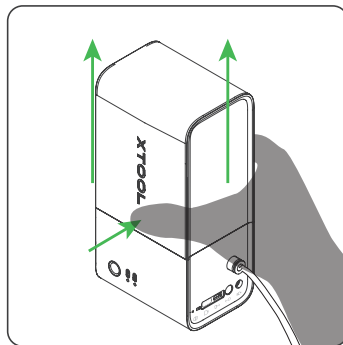

捏住盒子，然後向上拉

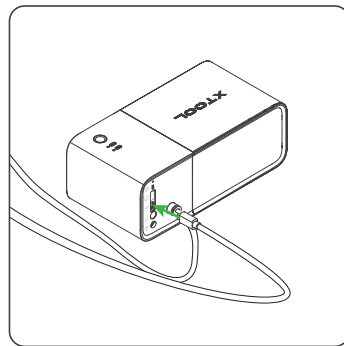
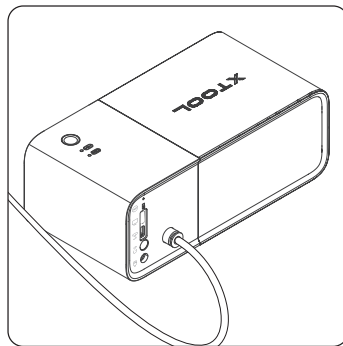
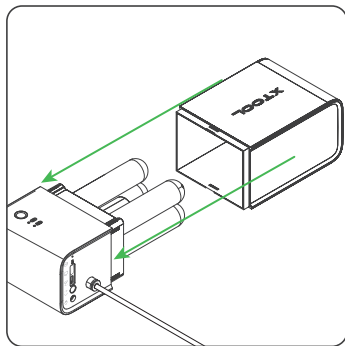
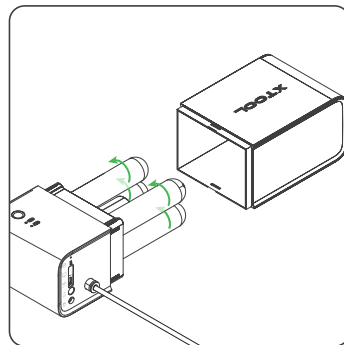

連接 USB 數據線

使用火焰安全裝置

進入工作狀態

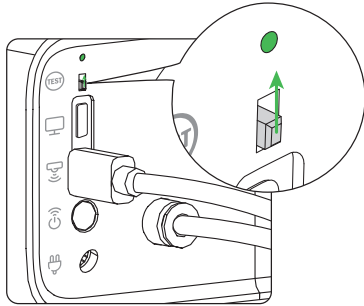

將開關撥到工作模式

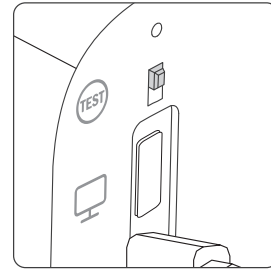

熄滅

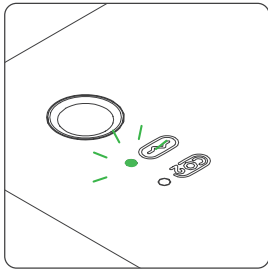

閃爍

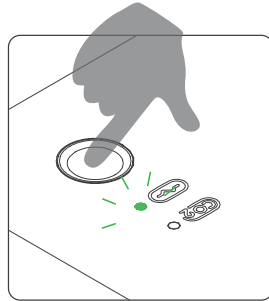

按下

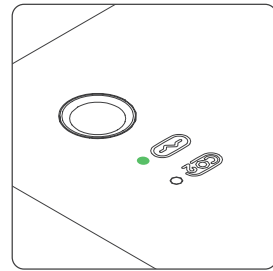

綠色恆亮，進入監測狀態

一鍵滅火

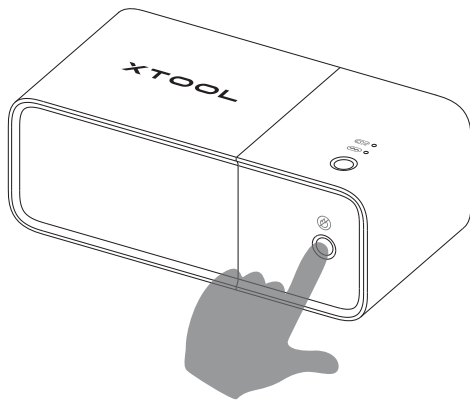

若在工作模式下發現火焰，而須手動滅火，可以按一鍵滅火按鈕，手動觸發滅火動作。

在滅火過程中，氣體會分兩次噴射，間隔約 20 秒。請待滅火過程結束，再觸碰控制盒。

滅火動作一旦觸發就無法取消，請謹慎操作。

更換氣瓶



- 若火焰安全裝置執行過滅火動作，換氣瓶指示燈亮，則須更換氣瓶才可繼續使用。氣瓶須另購。
- 在更換氣瓶前，請先拔出 USB 傳輸線，避免在更換過程中誤觸一鍵滅火按鈕，導致觸發滅火動作。

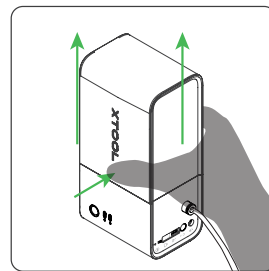
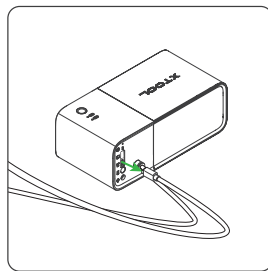
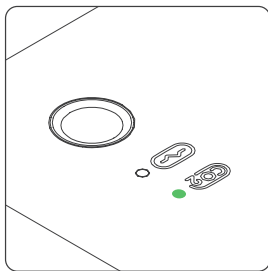

捏住盒子，然後向上拉

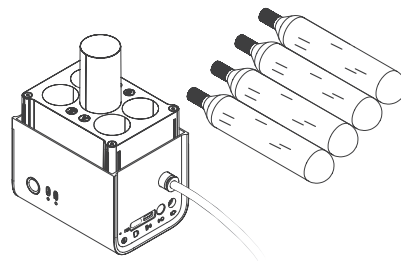
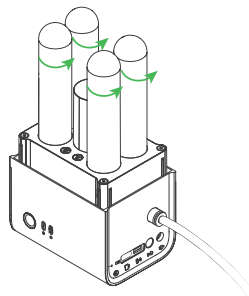

■ 設備加工空間 ≤ 0.065 立方公尺，可以選擇更換 2 個或 4 個氣瓶

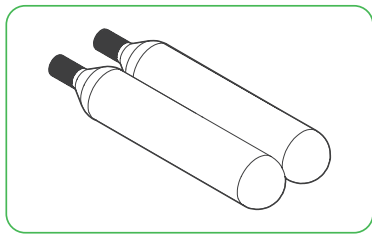

使用 2 個氣瓶時，請安裝在對角線上，例如，都安裝在孔 A，然後在另外一條對角線上的兩個孔位安裝空氣瓶。

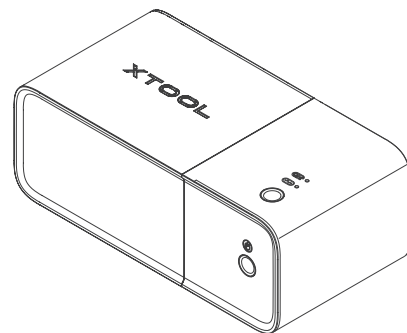
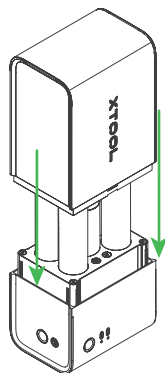
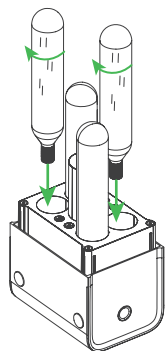
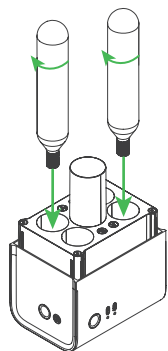

■ 0.065 立方公尺 < 設備加工空間 ≤ 0.13 立方公尺，須使用 4 個氣瓶

